

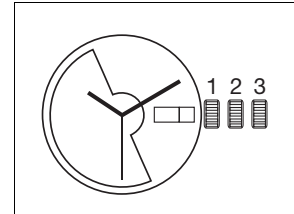

7 3/4''' ETA 2678

CT 2678 FDE 485879 12 20.11.2018

7 3/4''' Ø 17,20 mm



Hauteur sur mouvement	Höhe auf Werk	Movement height	5,35 mm
Réserve de marche	Gangreserve	Running time	mini: 38 h typique: 44 h
Nombre de rubis	Anzahl Rubine	Number of jewels	25
Angle de levée du balancier	Hebungswinkel der Unruh	Angle lift of balance	49°
Fréquence	Frequenz	Frequency	28'800 A/h

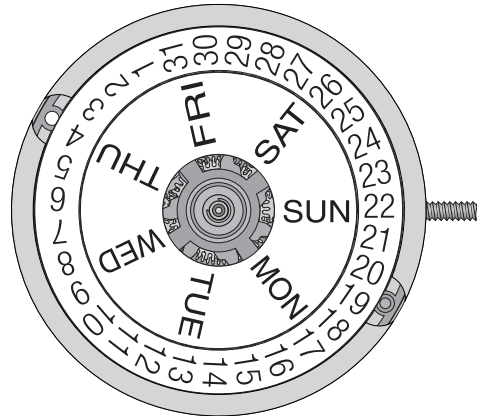
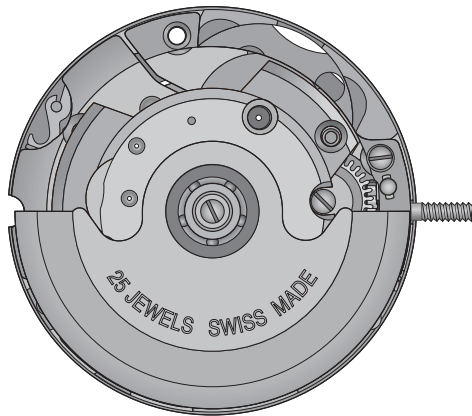

Les travaux de réparation et de révision ne doivent être effectués que par du personnel dûment formé.
Reparatur- und Revisionsarbeiten dürfen nur von ausgebildetem Fachpersonal ausgeführt werden.
The repair and reconditioning work must only be performed by properly trained personnel.



Informations générales



Avant de démarrer les travaux, veuillez svp étudier attentivement cette "*Communication technique*".



La protection des yeux est obligatoire pour toutes les interventions / tous les travaux sur le mouvement!



ETA SA décline toute responsabilité en cas de dommages du non respect de cette "*Communication technique*".

Exigences en matière de protection de l'environnement



Les dispositions légales en matière de traitement et d'élimination des déchets doivent être respectées lors de toutes les interventions / tous les travaux sur les mouvements!

En particulier, les produits de graissage et de nettoyage néfastes pour l'environnement doivent être éliminés selon les règles!



Les **substances de nature à polluer l'eau** doivent être entreposées, transportées, récupérées et éliminées dans des récipients adéquats.

Elles ne doivent en aucun cas polluer le sol ou être évacuées dans les réseaux de canalisation!

Explication des symboles



Attention! Risque de dégât matériel!

Ci-après quelques instructions à suivre obligatoirement pour éviter tout dégât matériel!



Ci-après quelques conseils d'utilisations et informations importantes.

Allgemeine Informationen



Diese "*Technische Mitteilung*" ist **vor** dem Beginn der Arbeiten genauestens zu studieren.



Für sämtliche Arbeiten am und mit dem Uhrwerk ist ein Augenschutz obligatorisch!



Für Schäden, welche durch Nichtbeachtung dieser "*Technischen Mitteilung*" entstehen, haftet die ETA SA nicht.

Umweltschutz-Vorschriften



Bei allen Arbeiten am und mit dem Uhrwerk sind die gesetzlichen Vorschriften zur ordnungsgemässen Verwertung und Beseitigung der Abfälle einzuhalten!

Insbesondere sind umweltgefährdende Schmier- und Reinigungsmittel ordnungsgemäss zu entsorgen!



Wassergefährdende Stoffe müssen in geeigneten Behältern aufbewahrt, transportiert, aufgefangen und entsorgt werden.

Diese dürfen nicht den Boden belasten oder in die Kanalisation gelangen!

Symbolerklärung



Achtung! Gefahr von Sachschäden!

Hier folgen wichtige Hinweise, die zur Vermeidung von Sachschäden unbedingt beachtet werden müssen!



Hier folgen Anwendungstipps und wichtige Informationen.

General information



Before starting work, please study this "*Technical communication*" carefully.



Eye protection is obligatory for all operations / work on the movement!



ETA SA disclaims any liability in case of damage arising from failure to observe this "*Technical communication*".

Environmental protection requirements



The legal provisions relating to waste handling and disposal must be observed in all operations / work on the movement!

In particular, lubricating and cleaning products harmful to the environment must be disposed of in accordance with the rules!



Substances prone to cause water pollution must be stored, transported, collected and disposed of in appropriate vessels.

They must not pollute the soil or be poured into sewage systems!

Explanation of symbols



Caution! Risk of material damage!

Below are some obligatory instructions for preventing any material damage!



Below are some application tips and important informations.

Liste des fournitures - Bestandteilliste - List of components

Pos	Numéro d'article Artikelnummer Article number		Liste des fournitures	Bestandteilliste	List of components
1	Var		Platine, montée	Werkplatte, montiert	Main plate, assembled
1-1	7613226056893	2x	Fixateur de cadran	Zifferblatthalter	Dial Fastener
1-2	7613226010765		Amortisseur empierré de balancier, à chasser, à portée, dessous INCABLOC	Stosssicherung mit Stein, für Unruh, zum Einpressen, mit Auflage, unten INCABLOC	Jewelled shock-absorber, for balance, shouldered, to press in, bottom INCABLOC
2	7613226054226		Pignon coulant	Kupplungstrieb	Sliding pinion
3	7613226050556		Pignon de remontoir	Aufzugtrieb	Winding pinion
4	Var		Tige de remontoir	Aufzugwelle	Winding stem
5	7613226038868		Levier de correcteur	Korrektorhebel	Corrector lever
6	7613226018556		Tirette	Winkelhebel	Setting lever
7	7613226009769		Bascule de pignon coulant	Kupplungstriebhebel	Yoke
8	7613226047631		Ressort de bascule	Kupplungshebelfeder	Yoke spring
9	7613226009097		Ressort de tirette	Winkelhebelfeder	Setting lever spring
10	7613226011380		Roue d'échappement	Hemmungsrads	Escape wheel
11	7613226051720		Roue intermédiaire	Zwischenrad	Intermediate wheel
12	7613226025004		Roue moyenne	Kleinbodenrad	Third wheel
13	Var		Roue de seconde	Sekundenrad	Second wheel
14	Var		Pont de rouage, empierré	Räderwerkbrücke, mit Steinen	Train wheel bridge, jewelled
15	Var		Barillet complet de mouvement	Federhaus vollständig für Grundwerk	Movement barrel complete
16	7613226022683		Levier stop	Stopphebel	Stop lever
17	Var		Pont de barillet, empierré	Federhausbrücke, mit Steinen	Barrel bridge, jewelled
18	7613226044432		Cliquet	Klinke	Click
19	7613226009332		Roue de couronne	Kronrad	Crown wheel
20	Var		Rochet	Sperrrad	Ratchet wheel
21	7613226038493		Ancre normalisée	Anker normalisiert	Pallet fork normalized
22	Var		Pont d'ancre, empierré	Ankerbrücke, mit Steinen	Pallet bridge, jewelled
23	7613226024694		Balancier réglé, avec piton	Unruh reguliert, mit Spiralklötzchen	Timed balance regulated, with stud
24	Var		Pont balancier monté	Unruh-Brücke montiert	Balance bridge, assembled
24-1	Var		Pont de balancier	Unruhbrücke	Balance bridge
24-2	7613226035645		Porte-Piton, monté	Spiralklötzchen-Träger, montiert	Stud support, assembled
24-3	7613226002760		Raquette inférieure montée	Unterer Rückerstift montiert	Lower index, assembled
24-4	7613226040991		Raquette supérieure	Oberer Rückerstift	Upper index
24-5	7613226010697		Correcteur de raquette	Rückerkorrektor	Regulator corrector
24-6	Var		Amortisseur empierré de balancier, à chasser, à portée, dessus	Stosssicherung mit Stein, für Unruh, zum Einpressen, mit Auflage, oben	Jewelled shock-absorber, for balance, shouldered, to press in, top
25	Var		Bâti du dispositif automatique, empierré	Gestell für Automatik, mit Steinen	Automatic device framework, jewelled
26	7613226055919		Roue entraîneuse de rochet	Mitnehmerrad für Sperrad	Ratchet wheel driving wheel
27	7613226042315		Roue auxiliaire d'inversion pour 17 & 25 rubis	Hilfs-Umkehrad für 17 & 25 Steine	Auxiliary reversing wheel for 17 & 25 jewels
28	7613226033740		Roue d'inversion	Umkehrad	Reversing wheel
29	7613226045231		Roue de réduction	Reduktionsrad	Reduction wheel
30	Var		Pont inférieur du dispositif automatique, empierré	Untere Brücke für Automatik, mit Steinen	Automatic device lower bridge, jewelled
31	Var		Masse oscillante, montée	Schwungmasse, montiert	Oscillating weight, assembled
31-1	Var		Masse oscillante	Schwungmasse	Oscillating weight
31-2	7613226027558		Roulement à billes	Kugellager	Ball bearing
32	7613226005655		Renvoi	Zeigerstellrad	Setting wheel
33	Var		Chaussée avec roue entraîneuse	Minutenrohr mit Antriebsrad	Cannon pinion with driving wheel
34	7613226055162		Roue de minuterie	Wechselrad	Minute wheel
35	7613226028234		Correcteur double, monté	Doppelkorrektor montiert	Double corrector assembled
36	7613226011717		Pont du rouage de minuterie	Wechselradbrücke	Minute train bridge
37	7613226018792		Roue entraîneuse du calendrier	Kalender-Mitnehmerrad	Calendar driving wheel
38	7613226003668		Roue intermédiaire de quantième	Datum-Zwischenrad	Intermediate date wheel
39	Var		Jeu indicateur quantième + jour	Datums- und Tagesanzeiger Satz	Date + day indicator set
40	7613226047648		Sautoir de quantième	Daturmaste	Date jumper
41	7613226036512		Plaque de maintien de quantième	Halteplatte für Datum	Maintaining plate for date
42	Var		Roue des heures	Stundenrad	Hour wheel
43	7613226018877		Ressort du sautoir des jours	Feder für Tagesraste	Day jumper spring
44	7613226040144		Sautoir des jours	Tagesraste	Day jumper
45	7613226044210		Correcteur des jours, monté	Tageskorrektor, montiert	Day corrector, assembled
46	Var		Jeu indicateur quantième + jour	Datums- und Tagesanzeiger Satz	Date + day indicator set
47	7613226050341		Clavette de l'indicateur du jour 0.150	Klemmscheibe für Tagesanzeiger 0.150	Day indicator spring-clip 0.150

Pos	Numéro d'article Artikelnummer Article number	Liste des fournitures	Bestandteilliste	List of components
48	7613226006898	Clavette de roue des heures 0.250	Klemmscheibe für Stundenrad 0.250	Hour wheel spring-clip 0.250
49	7613226035287	Support de cadran	Träger für Zifferblatt	Dial support
900	Var	Vis tête cônica	Senkschraube	Countersunk screw
		1x - Pos. 9: Vis de sautoir de tirette	- Pos. 9: Schraube für Winkelhebelraste	- Pos. 9: Screw for setting lever jumper
		2x - Pos. 14: Vis de pont de rouage	- Pos. 14: Schraube für Räderwerkbrücke	- Pos. 14: Screw for train wheel bridge
		3x - Pos. 17: Vis de pont de barillet	- Pos. 17: Schraube für Federhausbrücke	- Pos. 17: Screw for barrel bridge
		1x - Pos. 22: Vis de pont d'ancre	- Pos. 22: Schraube für Ankerbrücke	- Pos. 22: Screw for pallet bridge
		1x - Pos. 24: Vis de pont de balancier	- Pos. 24: Schraube für Unruhbrücke	- Pos. 24: Screw for balance bridge
		1x - Pos. 36: Vis de pont de rouage de minuterie	- Pos. 36: Schraube für Wechselradbrücke	- Pos. 36: Screw for minute train bridge
		1x - Pos. 41: Vis de plaque de maintien de l'indicateur quantième	- Pos 41: Schraube für Halteplatte für Datumanzeige	- Pos. 41: Screw for maintaining plate for date
901	Var	Vis collerette	Schraube mit Bord	Collar screw
		1x - Pos. 19: Vis de roue de couronne	- Pos. 19: Schraube für Kronrad	- Pos. 19: Screw for crown wheel
902	Var	Vis tête cylindrique	Zylinderkopfschraube	Cylindrical head screw
		1x - Pos. 20: Vis de rochet	- Pos. 20: Schraube für Sperrad	- Pos. 20: Screw for ratchet wheel
903	Var	Vis tête cônica	Senkschraube	Countersunk screw
		2x - Pos. 30: Vis de inférieur du dispositif automatique	- Pos. 30: Schraube für untere Brücke für Automatik	- Pos. 30: Screw for automatic device lower bridge
904	Var	Vis tête cônica	Senkschraube	Countersunk screw
		2x - Pos. 25: Vis de bâti du dispositif automatique	- Pos. 25: Schraube für Gestell für Automatik	- Pos. 25: Screw for automatic device framework
905	Var	Vis collerette	Schraube mit Bord	Collar screw
		1x - Pos. 31: Vis de roulement à billes	- Pos. 31: Schraube für Kugellager	- Pos. 31: Screw for ball bearing
906	7613226120174	Vis collerette nickelé(e)	Schraube mit Bord vernickelt	Collar screw nickel plated
		1x - Pos. 43: Vis du ressort du sautoir des jours	- Pos. 43: Schraube für Feder für Tagesraste	- Pos. 43: Screw for day jumper spring
		1x - Pos. 45: Vis de correcteur des jours	- Pos. 45: Schraube für Tageskorrektor	- Pos. 45: Screw for day corrector
	Var	Variante	Variante	Variant

L'interchangeabilité et les variantes se trouvent sur ETA ONLINE SHOP (EOS) :

www.eta.ch
→ Customer Service
→ Customer Service Portal



































































Die Austauschbarkeit und Varianten finden Sie im ETA ONLINE SHOP (EOS):

www.eta.ch
→ Customer Service
→ Customer Service Portal

Interchangeability and variants can be found on the ETA ONLINE SHOP (EOS):

www.eta.ch
→ Customer Service
→ Customer Service Portal

Fournitures - Bestandteile - Materials

									
1 Var	1-1	1-2	2	3	4 Var	5	6	7	8
									
9	10	11	12	13 Var	14 Var	15 Var	16	17 Var	18
									
19	20 Var	21	22 Var	23	24 Var	24-1 Var	24-2	24-3	24-4
									
24-5	24-6 Var	25 Var	26	27	28	29	30 Var	31 Var	31-1
									
31-2	32	33 Var	34	35	36	37	38	39 Var	40
									
41	42 Var	43	44	45	46 Var	47	48	49	
									
900 Var	901 Var	902 Var	903 Var	904 Var	905 Var	906			

Ordre d'assemblage - Montager Reihenfolge - Order of assembly:
 Mécanisme de mise à l'heure - Zeigerwerkmechanismus - Handsetting mechanism

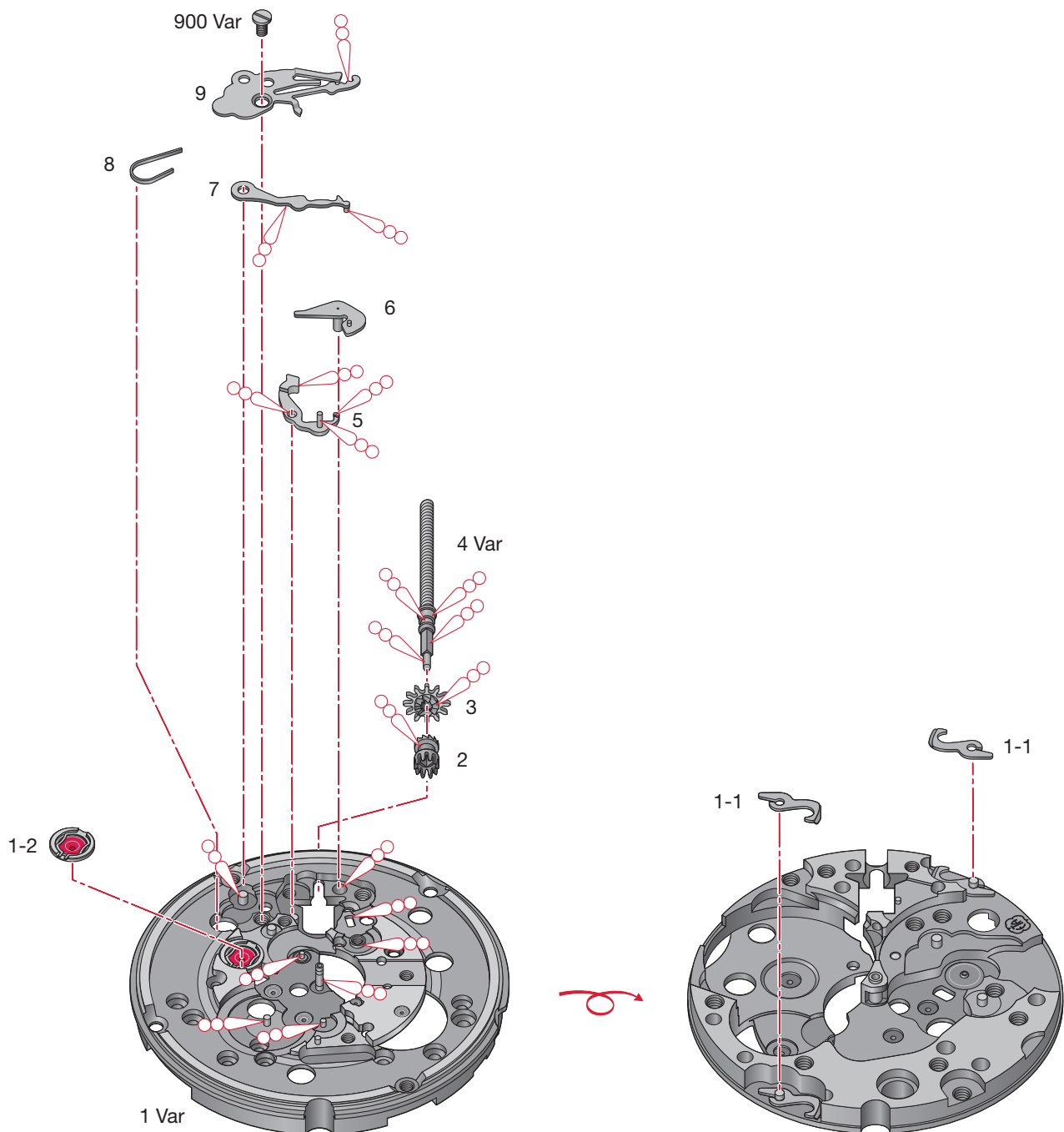

Montage du mécanisme de mise à l'heure

(Liste des fournitures par ordre d'assemblage)

Zusammenstellen des Zeigerwerkmechanismus

(Bestandteilliste in Montagereihenfolge)

Assembling of the handsetting mechanism

(Parts listed in order of assembly)

1 Var	5	9
2	6	900 Var (1x)
3	7	
4 Var	8	

Lubrification - Schmierung - Lubrication

 Huile épaisse
Dickflüssiges Öl
Thick oil

**Moebius
HP-1300**

Ordre d'assemblage - Montager Reihenfolge - Order of assembly:
 Mouvement de base et du mécanisme automatique - Basiswerk und Automatikmechanismus -
 Basic movement and self-winding mechanism

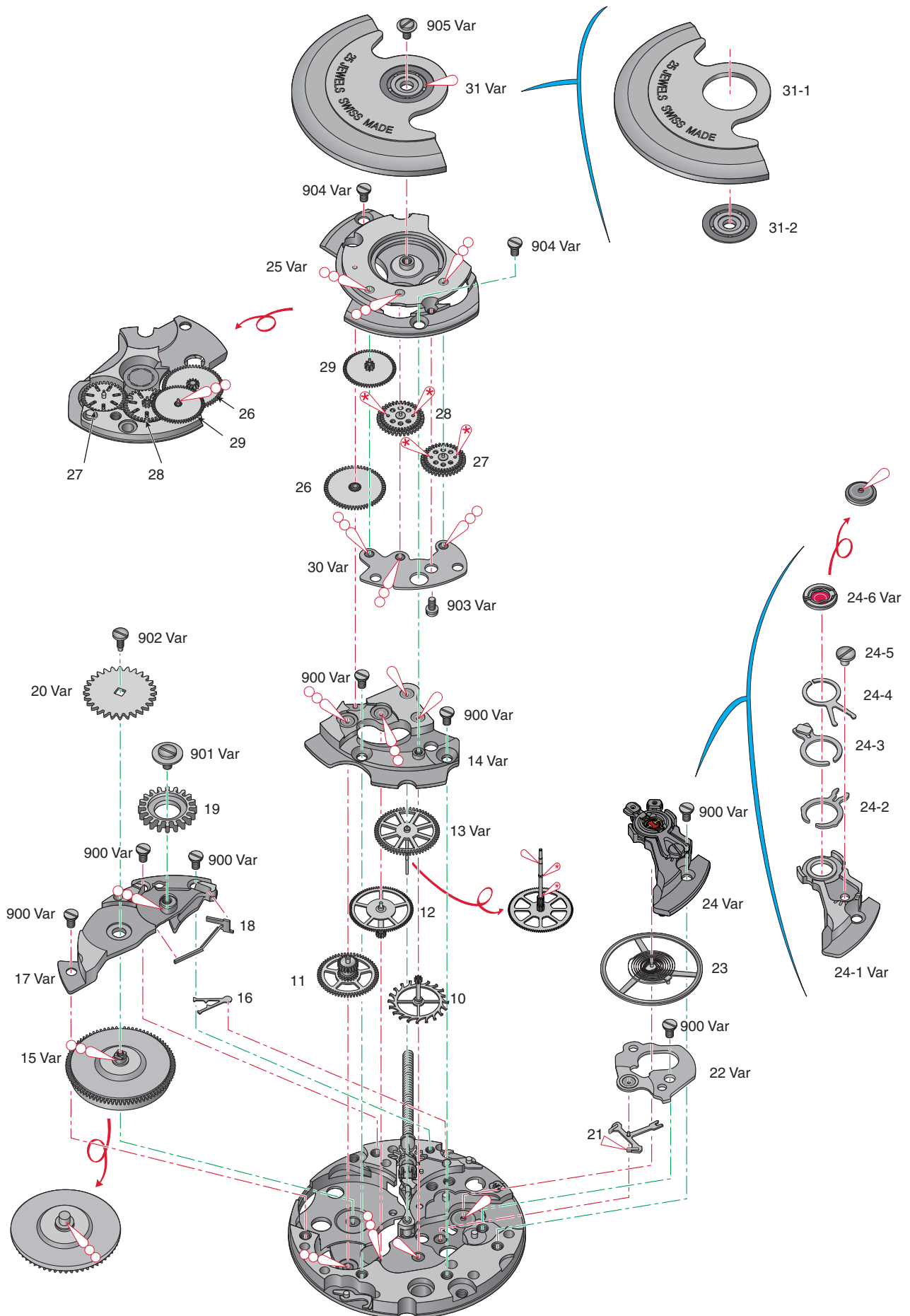

Montage du mouvement de base et du mécanisme automatique

(Liste des fournitures par ordre d'assemblage)

Zusammenstellen des Basiswerkes und des Automatikmechanismus

(Bestandteilliste in Montager Reihenfolge)

Assembling of the basic movement and the self-winding mechanism

(Parts listed in order of assembly)

10	901 Var (1x)	28
11	20 Var	29
12	902 Var (1x)	30 Var
13 Var	21	903 Var (1x)
14 Var	22 Var	904 Var (2x)
900 Var (2x)	900 Var (1x)	31 Var
15 Var	23	905 Var (1x)
16	24 Var	
17 Var	900 Var (1x)	
900 Var (3x)	25 Var	
18	26	
19	27	

Lubrification - Schmierung - Lubrication

 Huile fine
Dünnflüssiges Öl **Moebius 9010**
Fine oil

 Très faible quantité
Sehr kleine Menge **Moebius 9010**
Very small quantity

 Huile épaisse
Dickflüssiges Öl **Moebius HP-1300**
Thick oil

 Huile spéciale pour levées
Spezialöl für Hebungssteine **Moebius 9415**
Special oil for pallet stones

Ordre d'assemblage - Montager Reihenfolge - Order of assembly:
 Mécanisme de calendrier - Kalendermechanismus - Calendar mechanism

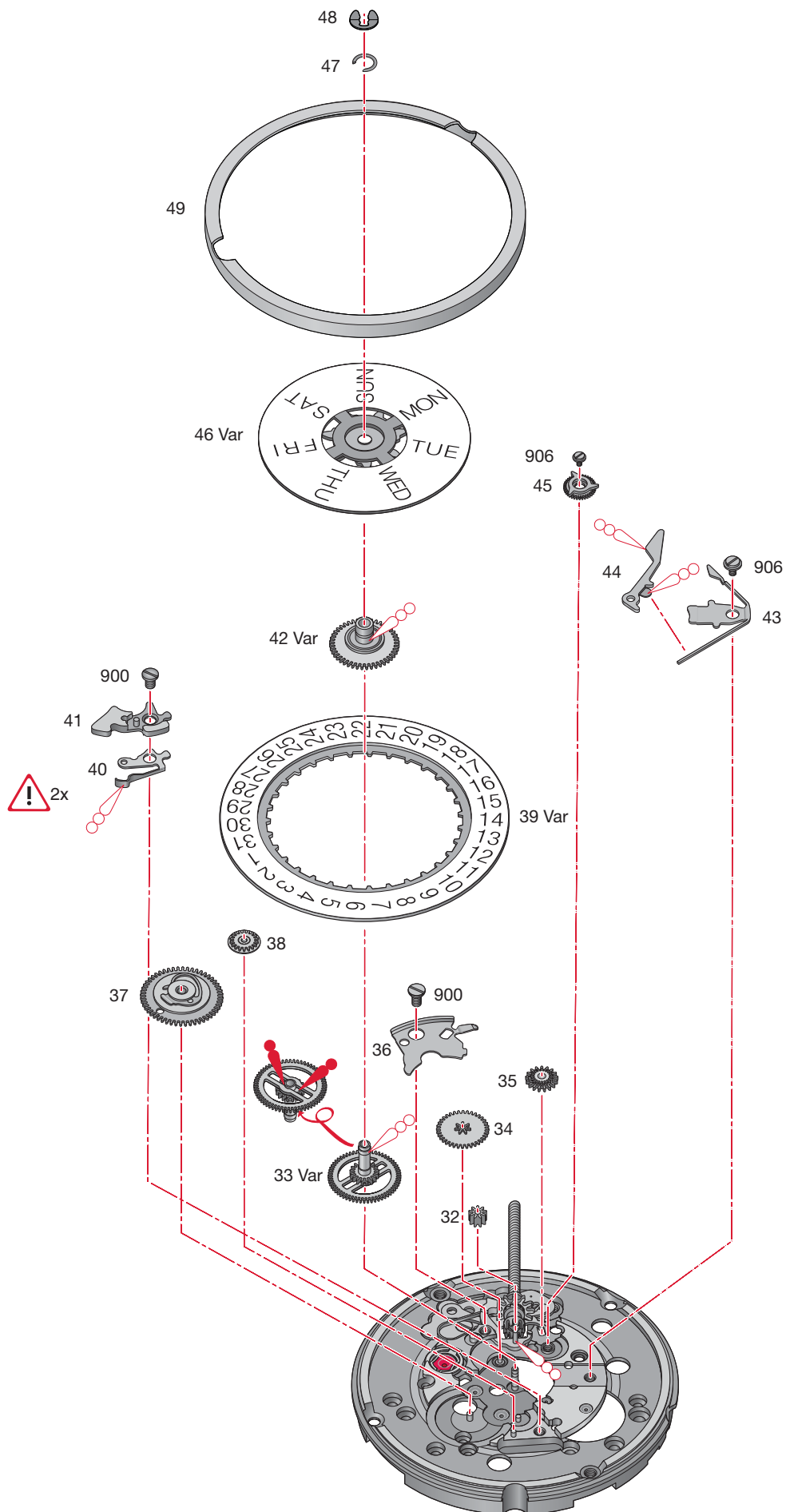

Montage du mécanisme de calendrier

(Liste des fournitures par ordre d'assemblage)

Zusammenstellen des Kalendermechanismus

(Bestandteilliste in Montagerihenfolge)

Assembling of the calendar mechanism

(Parts listed in order of assembly)

32	39 Var	45
33 Var	40	906 (1x)
34	41	46 Var
35	900 Var (1x)	47
36	42 Var	48
900 Var (1x)	43	49
37	906 (1x)	
38	44	

Lubrification - Schmierung - Lubrication

 Huile épaisse
Dickflüssiges Öl
Thick oil

**Moebius
HP-1300**

 Graisse
Fett
Grease

Moebius 9501

	Lubrifier la pièce 40. 1. Teil 40 schmieren. Lubricate part 40.
	Tourner la pièce 39 d'environ 10 dents avec la correction rapide. 2. Teil 39 mit Schnellkorrektur ca. 10 Zähne drehen. Rotate part 39 approx 10 teeth with rapide correction.
	Lubrifier à nouveau la pièce 40. 3. Teil 40 nochmals schmieren. Lubricate again part 40.
	Tourner à nouveau la pièce 39 d'environ 10 dents avec la correction rapide. 4. Teil 39 nochmals mit Schnellkor- rektur ca. 10 Zähne drehen. Rotate part 39 approx 10 teeth with rapide correction again.

Extraction de la tige de remontoir

Placer la tige de mise à l'heure en position 3 avant de presser légèrement, avec un outil, sur le point de la tirette (voir le schéma).

Entfernen der Aufzugwelle

Erst die Stellwelle in Position 3 platzieren, dann zum Lösen der Stellwelle mit einem Werkzeug leicht auf den Punkt auf dem Winkelhebel drücken (siehe auch Skizze).

Removing the winding stem

The handsetting stem must be placed in position 3 before pressing gently on the point of the lever using a tool to release the handsetting stem (see diagram).

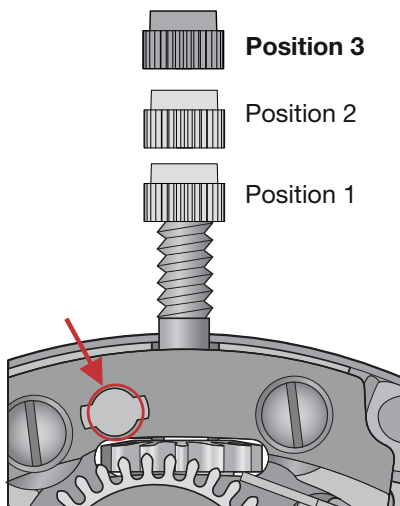

Mise en place du cliquet-ressort

Calibre à remontage automatique:

Fig. 2

Tenir le cliquet-ressort 434 par sa partie haute P, le glisser sous la roue de couronne suivant les flèches A – A et tourner la partie haute dans le sens de la flèche B. La mise en place est facilitée par une légère rotation de la tige de remontoir.

Setzen der Federklinke

Kaliber mit automatischem Aufzug:

Fig. 2

Die Federklinke 434 am höheren Teil P festhalten und in Pfeilrichtung A – A unter das Kronrad einschieben, den höheren Teil in Richtung des Pfeiles B abdrehen. Durch gleichzeitiges Drehen an der Aufzugwelle springt die Klinke leichter an ihren Platz.

Insetting the spring click

Automatic calibre:

Fig. 2

Hold the spring click 434 by its upper part P, slide it under the crown wheel following the arrows A – A and turn the upper part in the direction of arrow B, helping insert it by gently rotating the setting stem.

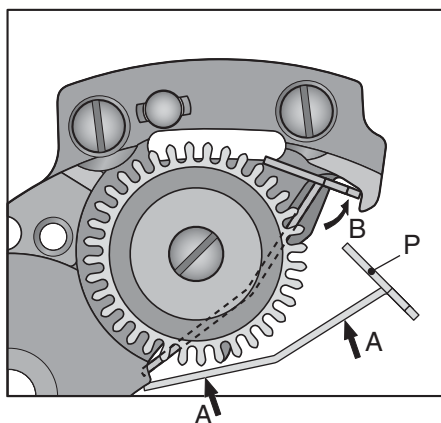

Fig. 2

Réglage et raquetterie

Angle de levée du balancier

Pour toutes les exécutions l'angle de levée du balancier est de 49°.

Raquetterie ETACHRON

Les réglages de rechange doivent être munis du piton ETA collé par ETA.

Pour enlever le piton du porte-piton C, le coq étant en place ou démonté, utiliser l'outil réf. 417.001.600 dans l'ouverture D, Fig. 3. Pousser avec précaution le piton hors de la fente.

Cet outil peut être commandé chez:

ETA SA Manufacture Horlogère Suisse
Customer Service
Bahnhofstrasse 9
2540 Grenchen
Switzerland

Phone +41 (0)32 655 27 77
cs@eta.ch
www.eta.ch

Le piton peut être réintroduit facilement à la manière d'un bouton-pression, avec, de préférence, le coq en place.

Le centrage de la lame du spiral se fait toujours par rotation du piton, sans déformer la lame (outil réf. 417.001.400).

Le jeu de la lame du spiral entre les goupilles de raquetterie peut être augmenté ou réduit à volonté par la rotation du bloc porte-goupilles B.

Regulierung und Rückersystem

Unruh-Hebungswinkel

Für alle Ausführungen beträgt der Hebungswinkel der Unruh 49°.

Rückersystem ETACHRON

Die Ersatzreglages müssen mit einem von ETA verleimten Spiralklötzchen bestückt sein.

Zum Entfernen des Spiralklötzchens aus dem Spiralklötzchen-Träger C, bei aufgeschraubtem oder demontiertem Unruhkolben, wird ein ETA-Werkzeug Ref. 417.001.600 bei der Öffnung D (Fig. 3) eingeschoben und das Spiralklötzchen vorsichtig aus der Schlitzöffnung gestossen.

Dieses Werkzeug kann bei folgender Adresse bestellt werden:

ETA SA Manufacture Horlogère Suisse
Customer Service
Bahnhofstrasse 9
2540 Grenchen
Switzerland

Phone +41 (0)32 655 27 77
cs@eta.ch
www.eta.ch

Das Spiralklötzchen kann leicht wieder eingerastet werden, in der Art eines Druckknopfes, vorteilhafterweise bei aufgeschraubtem Unruhkolben.

Das Zentrieren des Spiralklinge geschieht immer durch Drehen des Spiralklötzchens, ohne Verformen der Spiralklinge (Werkzeug Ref. 417.001.400).

Das Spiralfeder-Spiel zwischen den Rückerstiften kann nach Belieben erhöht oder reduziert werden durch Drehen des Rückerstift-Blockes B.

Balance and index assembly

Angle lift of balance

The angle of lift of the balance is 49° for all versions.

ETACHRON index assembly

Replacement balances must be equipped with the ETA stud glued by ETA.

To remove the stud from the stud holder C, with the balance-cock in place or taken down, use tool ref. 417.001.600 in the aperture D, Fig. 3. Carefully push the stud out of the slit.

This tool can be ordered from:

ETA SA Manufacture Horlogère Suisse
Customer Service
Bahnhofstrasse 9
2540 Grenchen
Switzerland

Phone +41 (0)32 655 27 77
cs@eta.ch
www.eta.ch

The stud can easily be put back in like a press-button, preferably with the balance-cock in place.

The blade of the balance-spring should always be centered by rotating the stud, without deforming the blade (tool ref. 417.001.400).

The play of the balance spring between the regulator pins can be increased or decreased as required by rotating the pinholder block B.

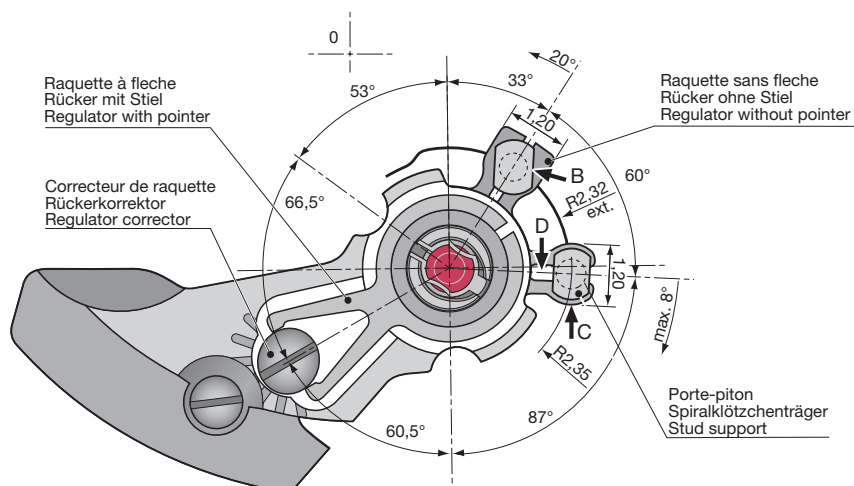



Pour des informations concernant les aiguillages voir:

Information Habillage

Plan:
AIGUILLAGES
ZEIGERWERKHÖHEN
HAND FITTING HEIGHTS



Für Informationen betreffend der Zeigerwerkhöhen siehe:

Fabrikanten Information

Zeichnung:
AIGUILLAGES
ZEIGERWERKHÖHEN
HAND FITTING HEIGHTS



For information regarding hand fitting heights see:

Manufacturing Information

Drawing:
AIGUILLAGES
ZEIGERWERKHÖHEN
HAND FITTING HEIGHTS

Cette page est laissée vide
intentionnellement en cas d'impression
au format A3.

Diese Seite wird absichtlich leer
gelassen für den Fall, dass im
A3-Format gedruckt wird.

This page has deliberately been
left blank in case of A3 format
printing.

**Modifications comparées aux versions
précédentes du document****Änderungen gegenüber vorher-
gehenden Dokumentversionen****Modifications compared with previous
document versions**

Version	Date Datum Date	Modification	Änderung	Modification	Page Seite Page
12	20.11.2018	Adaptation texte	Anpassung Text	Adaptation text	12
11	10.04.2018	Ordre d'assemblage	Montagereihenfolge	Order of assembly	3-11
10	24.03.2016	Correction: angle de levée du balancier	Korrektur: Hebungswinkel der Unruh	Correction: angle lift of balance	1, 13
09	20.01.2010	Modification montage	Aenderung Montage	Modification Montage	6-11
08	05.05.2009	Modification fournitures	Aenderung Komponenten	Modification components	3-5
08	05.05.2009	Répartition des calibres	Aufteilung pro Kaliber	Allocation per caliber	1-12
07	19.05.2008	Version de base	Basis Version	Basic version	--

Sous réserve de toutes modifications.

Änderungen vorbehalten.

All modifications reserved.

**Ce document se trouve sur le
Customer Service Portal (CSP) :**

www.eta.ch

- Customer Service
- Customer Service Portal
- Documents techniques

**Dieses Dokument finden Sie im
Customer Service Portal (CSP):**

www.eta.ch

- Customer Service
- Customer Service Portal
- Technische Dokumente

**This document can be found on the
Customer Service Portal (CSP):**

www.eta.ch

- Customer Service
- Customer Service Portal
- Technical Documents



ETA^{SA}
MANUFACTURE HORLOGÈRE SUISSE
DEPUIS 1793

SC MARKETING & COMMUNICATION

Bahnhofstrasse 9
2540 Grenchen
Switzerland

Phone +41 (0)32 655 71 11

contact@eta.ch
www.eta.ch